

## DS50EV401

# 2.5 Gbps / 5.0 Gbps or 8.0 Gbps Quad PCI Express Cable and Backplane Equalizer

### General Description

The DS50EV401 is a low power, programmable equalizer specifically designed for PCI Express applications. The device provides 2 equalization settings to reduce inter-symbol interference (ISI) induced by a variety of interconnect media. One setting is optimized for PCIe Gen1 and Gen2 applications; the other is optimized for future Gen3 data rates. In all modes, the equalizer can operate, error free, with an input eye that is completely closed by interconnect ISI. The MODE, allows the user to select between equalization settings for 8Gbps operation or 2.5Gbps / 5.0Gbps operation.

The DS50EV401 enables PCI Express compatible link extension by supporting transmit electrical idle, and Beacon signal pass through on a per lane basis. Current-mode logic (CML) is used on both input and output ports, which provide constant 50 ohm single-ended impedance to AC ground. Differential signaling is implemented through out the entire signal path to minimize supply induced jitter. The DS50EV401 is available in a 7mm x 7mm 48-pin leadless LLP package, and is powered from a single power supply of either 3.3 or 2.5V.

### Features

- PCI Express compatible Equalizer
- Automatic power management on an individual lane basis
- Data rate optimized equalization
- Operates over 7 meter of 24 AWG PCI Express Cables up to 8 Gbps
- Typical residual deterministic jitter:
  - 0.18 UI @ 8 Gbps w/ 30" of FR4
  - 0.18 UI @ 5 Gbps w/ 40" of FR4
  - 0.16 UI @ 2.5 Gbps w/ 40" of FR4
- 8 kV HBM ESD protection
- -40 to 85°C operating temperature range
- 7 mm x 7 mm 48-pin leadless LLP package
- Single power supply of either 3.3V or 2.5V
- Low power (typically 95 mW per channel at 2.5V  $V_{DD}$ )

### Application Diagram

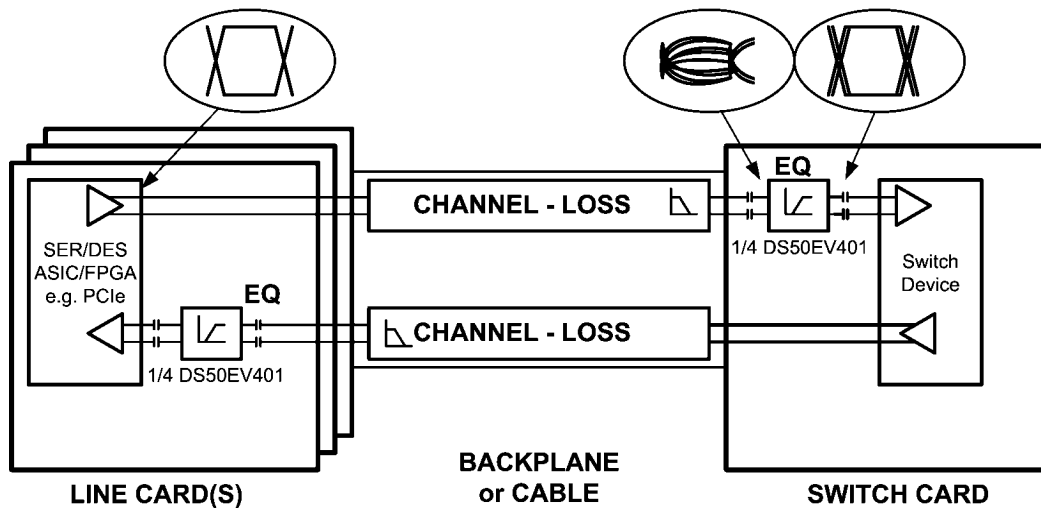

30050550

## Pin Descriptions

| Pin Name                           | Pin Number | I/O, Type | Description   |
|------------------------------------|------------|-----------|---|
| <b>HIGH SPEED DIFFERENTIAL I/O</b> |            |           |   |
| IN_0+                              | 1          | I, CML    | Inverting and non-inverting CML differential inputs to the equalizer. An on-chip 50Ω terminating resistor connects IN_0+ to VDD and IN_0- to VDD.                               |
| IN_0-                              | 2          |           |   |
| IN_1+                              | 4          | I, CML    | Inverting and non-inverting CML differential inputs to the equalizer. An on-chip 50Ω terminating resistor connects IN_1+ to VDD and IN_1- to VDD.                               |
| IN_1-                              | 5          |           |   |
| IN_2+                              | 8          | I, CML    | Inverting and non-inverting CML differential inputs to the equalizer. An on-chip 50Ω terminating resistor connects IN_2+ to VDD and IN_2- to VDD.                               |
| IN_2-                              | 9          |           |   |
| IN_3+                              | 11         | I, CML    | Inverting and non-inverting CML differential inputs to the equalizer. An on-chip 50Ω terminating resistor connects IN_3+ to VDD and IN_3- to VDD.                               |
| IN_3-                              | 12         |           |   |
| OUT_0+                             | 36         | O, CML    | Inverting and non-inverting CML differential outputs from the equalizer. An on-chip 50Ω terminating resistor connects OUT_0+ to V <sub>DD</sub> and OUT_0- to V <sub>DD</sub> . |
| OUT_0-                             | 35         |           |   |
| OUT_1+                             | 33         | O, CML    | Inverting and non-inverting CML differential outputs from the equalizer. An on-chip 50Ω terminating resistor connects OUT_1+ to V <sub>DD</sub> and OUT_1- to V <sub>DD</sub> . |
| OUT_1-                             | 32         |           |   |
| OUT_2+                             | 29         | O, CML    | Inverting and non-inverting CML differential outputs from the equalizer. An on-chip 50Ω terminating resistor connects OUT_2+ to V <sub>DD</sub> and OUT_2- to V <sub>DD</sub> . |
| OUT_2-                             | 28         |           |   |
| OUT_3+                             | 26         | O, CML    | Inverting and non-inverting CML differential outputs from the equalizer. An on-chip 50Ω terminating resistor connects OUT_3+ to V <sub>DD</sub> and OUT_3- to V <sub>DD</sub> . |
| OUT_3-                             | 25         |           |   |
| <b>EQUALIZATION CONTROL</b>        |            |           |   |
| MODE                               | 14         | I, LVCMOS | MODE selects the equalizer frequency for EQ channels. MODE is internally pulled low.<br>L = 8Gbps setting<br>H = 2.5Gbps / 5.0Gbps setting                                      |
| <b>DEVICE CONTROL</b>              |            |           |   |
| EN0                                | 44         | I, LVCMOS | Channel 0 Enable Input Pin<br>H = normal operation (enabled)<br>L = standby mode<br>Pin is internally pulled High.  |
| EN1                                | 42         | I, LVCMOS | Channel 1 Enable Input Pin<br>H = normal operation (enabled)<br>L = standby mode<br>Pin is internally pulled High.  |
| EN2                                | 40         | I, LVCMOS | Channel 2 Enable Input Pin<br>H = normal operation (enabled)<br>L = standby mode<br>Pin is internally pulled High.  |
| EN3                                | 38         | I, LVCMOS | Channel 3 Enable Input Pin<br>H = normal operation (enabled)<br>L = standby mode<br>Pin is internally pulled High.  |
| SD0                                | 45         | O, LVCMOS | Channel 0 Signal Detect Output Pin<br>H = signal detected<br>L = no signal detected   |
| SD1                                | 43         | O, LVCMOS | Channel 1 Signal Detect Output Pin<br>H = signal detected<br>L = no signal detected   |
| SD2                                | 41         | O, LVCMOS | Channel 2 Signal Detect Output Pin<br>H = signal detected<br>L = no signal detected.  |
| SD3                                | 39         | O, LVCMOS | Channel 3 Signal Detect Output Pin<br>H = signal detected<br>L = no signal detected   |

| Pin Name        | Pin Number                             | I/O, Type | Description   |
|-----------------|--|-----------|---|
| <b>POWER</b>    |  |           |   |
| V <sub>DD</sub> | 3, 6, 7, 10, 13, 15, 46                | Power     | V <sub>DD</sub> = 2.5V ± 5% or 3.3V ± 10%. V <sub>DD</sub> pins should be tied to V <sub>DD</sub> plane through low inductance path. A 0.1µF bypass capacitor should be connected between each V <sub>DD</sub> pin to GND planes. |
| GND             | 22, 24, 27, 30, 31, 34                 | Ground    | Ground reference. GND should be tied to a solid ground plane through a low impedance path.  |
| Exposed Pad     | DAP                                    | Ground    | Ground reference. The exposed pad at the center of the package must be connected to ground plane of the board.  |
| <b>OTHER</b>    |  |           |   |
| Reserv          | 16, 17, 18, 19, 20, 21, 23, 37, 47, 48 |           | Reserved. Do not connect. Leave open.   |

Note: I = Input O = Output

### Connection Diagram

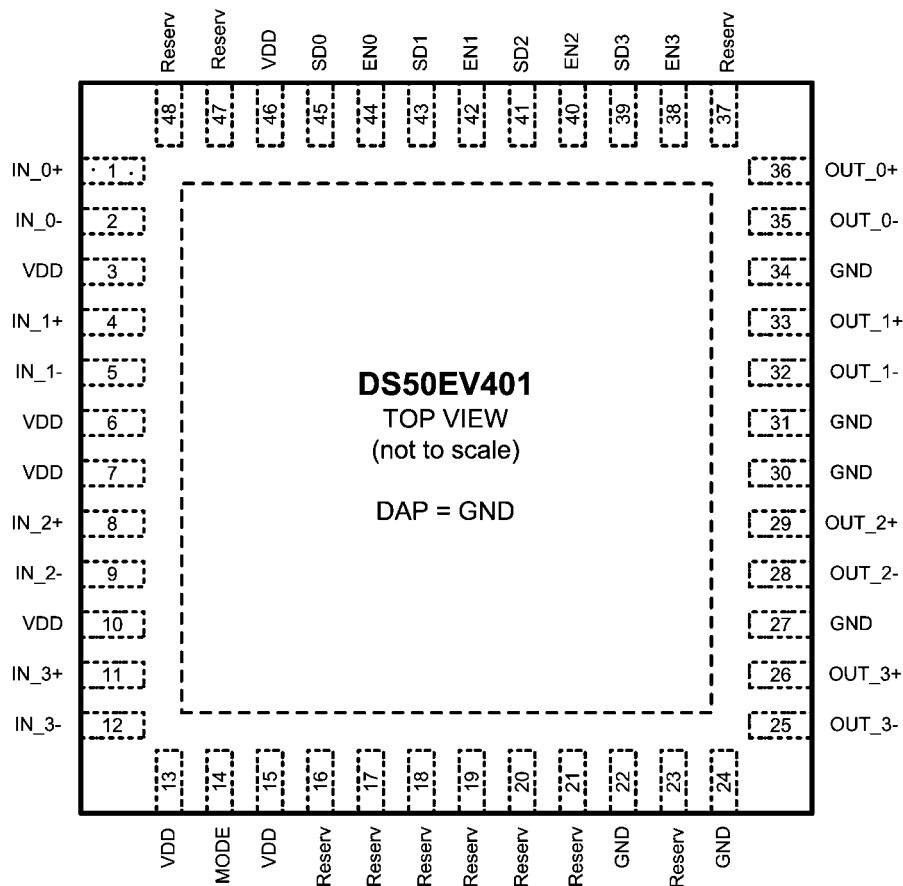

30050526

TOP VIEW — Not to scale

### Ordering Information

| NSID         | Package             | Tape & Reel QTY | Package Number |
|--------------|---------------------|-----------------|----------------|
| DS50EV401SQ  | 48 Lead LLP Package | 1,000           | SQA48D         |
| DS50EV401SQE | 48 Lead LLP Package | 250             | SQA48D         |
| DS50EV401SQX | 48 Lead LLP Package | 2,500           | SQA48D         |

**Absolute Maximum Ratings** (Note 1)

If Military/Aerospace specified devices are required, please contact the National Semiconductor Sales Office/ Distributors for availability and specifications.

|                             |                |
|-----------------------------|----------------|
| Supply Voltage ( $V_{DD}$ ) | -0.5V to +4.0V |
| LVC MOS Input Voltage       | -0.5V + 4.0V   |
| LVC MOS Output Voltage      | -0.5V to 4.0V  |
| CML Input/Output Voltage    | -0.5V to 4.0V  |

|                      |                 |
|----------------------|-----------------|
| Junction Temperature | +150°C          |
| Storage Temperature  | -65°C to +150°C |

ESD Rating

HBM, 1.5 k $\Omega$ , 100 pF

&gt;8 kV

Thermal Resistance

 $\theta_{JA}$ , No Airflow

30°C/W

**Recommended Operating Conditions**

|                     | Min   | Typ | Max   | Units |
|---------------------|-------|-----|-------|-------|
| Supply Voltage      |       |     |       |       |
| $V_{DD}$ to GND, or | 2.375 | 2.5 | 2.625 | V     |
| $V_{DD}$ to GND     | 3.0   | 3.3 | 3.6   | V     |
| Ambient Temperature | -40   | 25  | +85   | °C    |

**Electrical Characteristics**

Over recommended operating supply and temperature ranges with default register settings unless other specified. (Notes 2, 3)

| Symbol  | Parameter                              | Conditions  | Min  | Typ  | Max      | Units             |
|---|--|---|------|------|----------|-------------------|
| <b>POWER</b>  |  |   |      |      |          |                   |
| PD  | Power Dissipation<br>3.3V Operation    | Signal active, $V_{DD} = 3.3V, 3.6V$  |      | 510  | 700      | mW                |
|   |  | No signal, $V_{DD} = 3.3V, 3.6V$  |      |      | 100      | mW                |
| PD  | Power Dissipation<br>2.5V Operation    | Signal active, $V_{DD} = 2.5V, 2.625V$  |      | 380  | 490      | mW                |
|   |  | No signal, $V_{DD} = 2.5V, 2.625V$  |      | 30   |          | mW                |
| N   | Supply Noise Tolerance<br>(Note 4)     | Up to 50 MHz  |      | 100  |          | mV <sub>P-P</sub> |
| <b>LVC MOS / LVTTL DC SPECIFICATIONS</b>                      |  |   |      |      |          |                   |
| $V_{IH}$  | High Level Input Voltage               | 3.3V Operation  | 2.0  |      | $V_{DD}$ | V                 |
|   |  | 2.5V Operation  | 1.6  |      | $V_{DD}$ | V                 |
| $V_{IL}$  | Low Level Input Voltage                |   | -0.3 |      | 0.8      | V                 |
| $V_{OH}$  | High Level Output Voltage              | $I_{OH} = -3mA, 3.3V$ Operation   | 2.4  |      |          | V                 |
|   |  | $I_{OH} = -3mA, 2.5V$ Operation   | 2.0  |      |          | V                 |
| $V_{OL}$  | Low Level Output Voltage               | $I_{OL} = 3mA$  |      |      | 0.4      | V                 |
| $I_{IH}$  | Input High Current                     | $V_{IN} = V_{DD}$ , MODE pin (pull down)  |      |      | +140     | $\mu A$           |
|   |  | $V_{IN} = V_{DD}$ , EN pins (pull up)   | -15  |      | +15      | $\mu A$           |
| $I_{IL}$  | Input Low Current                      | $V_{IN} = 0V$ , MODE pin (pull down)  | -15  |      | +15      | $\mu A$           |
|   |  | $V_{IN} = 0V$ , EN pins (pull up)   | -40  |      |          | $\mu A$           |
| <b>CML RECEIVER INPUTS (IN<sub>n+</sub>, IN<sub>n-</sub>)</b> |  |   |      |      |          |                   |
| $V_{TX}$  | Input Voltage Swing (Launch Amplitude) | Measured at point A, AC or DC coupled, <i>Figure 1</i>  | 400  | 1000 | 1600     | mV <sub>P-P</sub> |
| $V_{IN-S}$  | Input Voltage Sensitivity              | AC-Coupled or DC-Coupled<br>Required Differential Envelope<br>measured at point B, <i>Figure 1</i> ,<br>(Note 5), See <i>FR4 / BACKPLANE<br/>Typical Performance Eye<br/>Diagrams</i> , |      | 170  |          | mV <sub>P-P</sub> |
| $R_{LI}$  | Differential Input Return Loss         | 100 MHz – 4.0 GHz, with fixture's<br>effect de-embedded   |      | 10   |          | dB                |
| $R_{IN}$  | Input Resistance                       | Single ended to $V_{DD}$  | 40   | 50   | 60       | $\Omega$          |

| Symbol                              | Parameter                                  | Conditions  | Min | Typ                    | Max  | Units             |
|-------------------------------------|--|---|-----|------------------------|------|-------------------|
| <b>CML OUTPUTS (OUT_n+, OUT_n-)</b> |  |   |     |                        |      |                   |
| V <sub>O</sub>                      | Output Voltage Swing                       | Differential measurement with OUT_n+ and OUT_n- terminated by 50Ω to GND AC-Coupled, <i>Figure 2</i>              | 800 | 1000                   | 1200 | mV <sub>P-P</sub> |
| V <sub>OCM</sub>                    | Output Common-Mode Voltage                 | Single-ended measurement DC-Coupled with 50Ω termination, (Note 6)  |     | V <sub>DD</sub> - 0.25 |      | V                 |
| t <sub>R</sub> , t <sub>F</sub>     | Transition Time                            | 20% to 80% of differential output voltage, measured within 1" from output pins, <i>Figure 2</i> , (Note 6)        |     | 40                     |      | ps                |
| R <sub>O</sub>                      | Output Resistance                          | Single-ended to V <sub>DD</sub>   | 40  | 50                     | 60   | Ω                 |
| R <sub>LO</sub>                     | Differential Output Return Loss            | 100 MHz – 4.0 GHz, with fixture's effect de-embedded. IN_n+ = static high   |     | 10                     |      | dB                |
| t <sub>PLHD</sub>                   | Differential Low to High Propagation Delay | Propagation delay measurement at 50% V <sub>O</sub> between input to output, 100 Mbps, <i>Figure 3</i> , (Note 8) |     | 240                    |      | ps                |
| t <sub>PHLD</sub>                   | Differential High to Low Propagation Delay |   |     | 240                    |      | ps                |
| t <sub>ID</sub>                     | Idle to Valid Differential Data            | V <sub>IN</sub> = 800 mVp-p, 5 Gbps, EIEOS, 40" of 6 mil microstrip FR4, <i>Figure 4</i> , (Note 6)               |     | 8                      |      | ns                |
| t <sub>DI</sub>                     | Valid Differential data to idle            | V <sub>IN</sub> = 800 mVp-p, 5 Gbps, EIOS, 40" of 6 mil microstrip FR4, <i>Figure 4</i> , (Note 6)                |     | 8                      |      | ns                |
| t <sub>CCSK</sub>                   | Inter Pair Channel to Channel Skew         | Difference in 50% crossing between channels   |     | 7                      |      | ps                |
| <b>EQUALIZATION</b>                 |  |   |     |                        |      |                   |
| DJ1                                 | Residual Deterministic Jitter at 8 Gbps    | 30" of 6 mil microstrip FR4, MODE=0, PRBS-7 (2 <sup>7</sup> -1) pattern, (Notes 6, 7)                             |     | 0.18                   |      | UI <sub>P-P</sub> |
| DJ2                                 | Residual Deterministic Jitter at 5 Gbps    | 40" of 6 mil microstrip FR4, MODE=1, PRBS-7 (2 <sup>7</sup> -1) pattern, (Notes 6, 7)                             |     | 0.18                   | 0.21 | UI <sub>P-P</sub> |
| DJ3                                 | Residual Deterministic Jitter at 2.5 Gbps  | 40" of 6 mil microstrip FR4, MODE=1, PRBS-7 (2 <sup>7</sup> -1) pattern, (Notes 6, 7)                             |     | 0.16                   | 0.18 | UI <sub>P-P</sub> |
| RJ                                  | Random Jitter                              | (Notes 8, 9)  |     | 0.5                    |      | psrms             |

**Note 1:** "Absolute Maximum Ratings" indicate limits beyond which damage to the device may occur, including inoperability and degradation of device reliability and/or performance. Functional operation of the device and/or non-degradation at the Absolute Maximum Ratings or other conditions beyond those indicated in the Recommended Operating Conditions is not implied. The Recommended Operating Conditions indicate conditions at which the device is functional and the device should not be operated beyond such conditions. Absolute Maximum Numbers are guaranteed for a junction temperature range of -40°C to +125°C. Models are validated to Maximum Operating Voltages only.

**Note 2:** Typical values represent most likely parametric norms at V<sub>DD</sub> = 3.3V or 2.5V, T<sub>A</sub> = 25°C., and at the Recommended Operation Conditions at the time of product characterization and are not guaranteed.

**Note 3:** The Electrical Characteristics tables list guaranteed specifications under the listed Recommended Operating Conditions except as otherwise modified or specified by the Electrical Characteristics Conditions and/or Notes. Typical specifications are estimations only and are not guaranteed.

**Note 4:** Allowed supply noise (mV<sub>P-P</sub> sine wave) under typical conditions.

**Note 5:** V<sub>IN-S</sub> is a measurement of the input differential envelope, see *FR4 / BACKPLANE Typical Performance Eye Diagrams*. The device does not require an open eye.

**Note 6:** Specification is guaranteed by characterization at optimal MODE setting and is not tested in production.

**Note 7:** Deterministic jitter is measured at the differential outputs (point C of *Figure 1*), minus the deterministic jitter before the test channel (point A of *Figure 1*). Random jitter is removed through the use of averaging or similar means.

**Note 8:** Measured with clock-like {11111 00000} pattern.

**Note 9:** Random jitter contributed by the equalizer is defined as sqrt (J<sub>OUT</sub><sup>2</sup> - J<sub>IN</sub><sup>2</sup>). J<sub>OUT</sub> is the random jitter at equalizer outputs in ps-rms, see point C of *Figure 1*; J<sub>IN</sub> is the random jitter at the input of the equalizer in ps-rms, see point B of *Figure 1*.

# Timing Diagrams

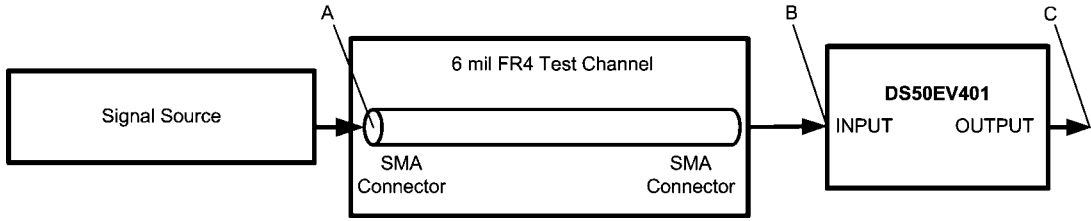

30050527

FIGURE 1. Test Setup Diagram

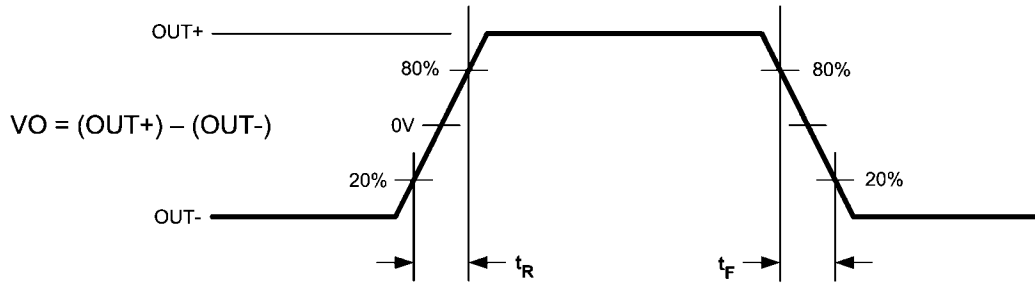

30050502

FIGURE 2. CML Output Transition Times

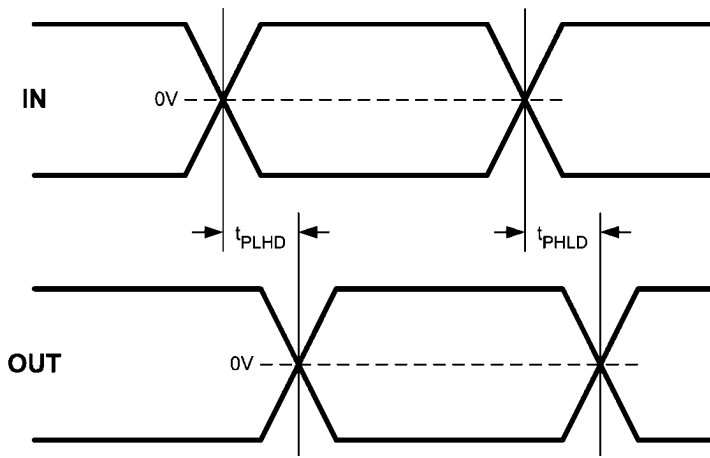

30050503

FIGURE 3. Propagation Delay Timing Diagram

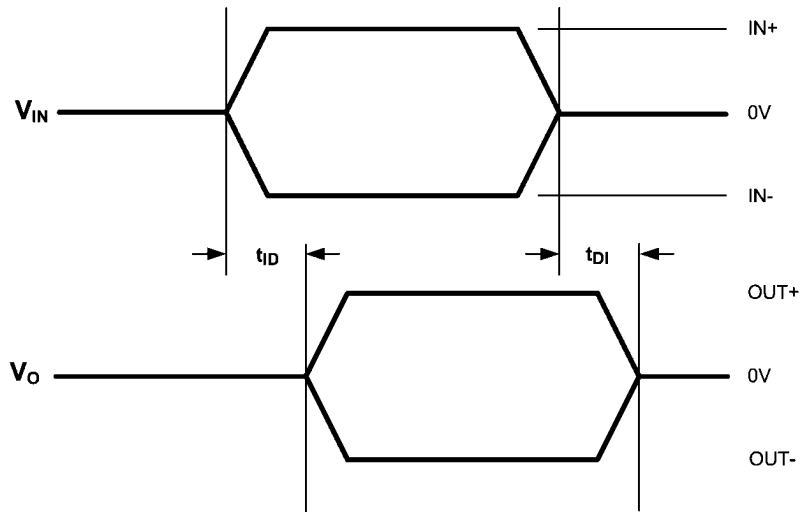

30050504

FIGURE 4. Idle Timing Diagram

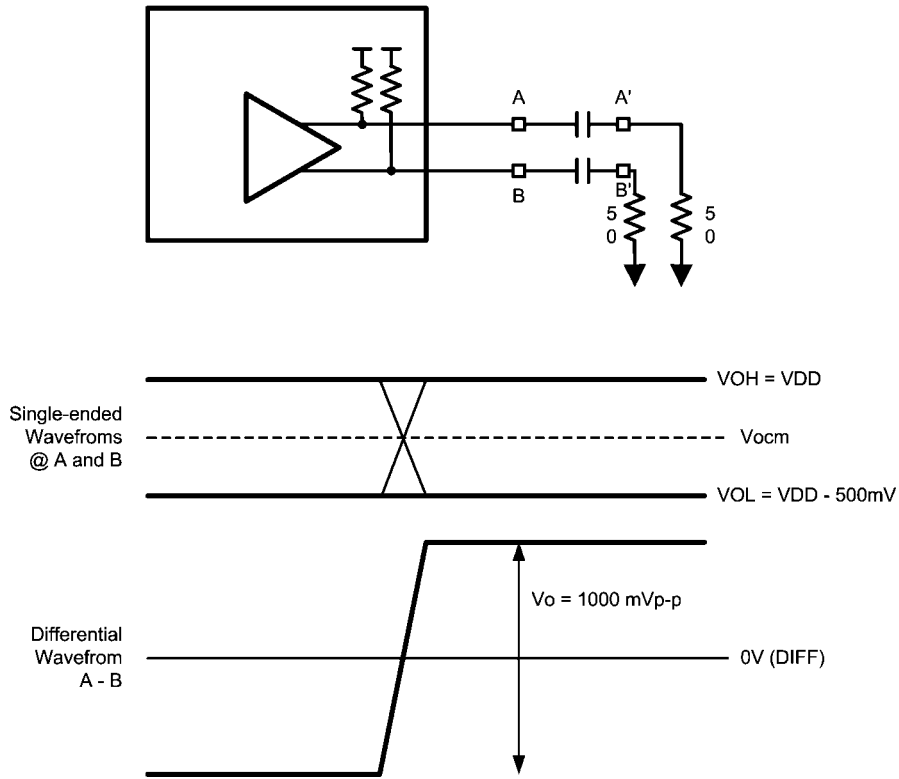

30050560

FIGURE 5. CML Output Swings at A/B

# Functional Description

## DS50EV401 APPLICATIONS INFORMATION

The DS50EV401 is a programmable quad equalizer optimized for PCI Express applications. It is designed to operate over copper backplanes and cables at transmission rates of 2.5 Gbps up to 8 Gbps. The device consists of an input receiver equalizer followed by a limiting amplifier. The equalizer is designed to open an input eye that is completely closed due to inter-symbol interference (ISI) induced by the channel interconnect. The equalization is set to keep residual deterministic jitter below 0.2 unit intervals (UI) regardless of data rate. This equalization scheme allows one equalization setting to satisfy both Gen1 and Gen2 links, eliminating the need for interaction between the equalizer and PCI Express endpoint

during link negotiation. The DS50EV401 is intended as a uni-directional receiver that should be placed in close physical proximity to the end point. Therefore the transmitter does not include de-emphasis as TX equalization would not be needed over the short distance between the equalizer and the end point.

In order to enable PCI compliant link extension the DS50EV401 will put the transmitter into electrical idle mode when no active data is sensed on its inputs. Idle is controlled on a per lane basis, and is solely dependent on activity of a particular channel's input activity. 50 ohm termination is maintained on both the RX and TX terminals in electrical idle mode. The DS50EV401 internal signal path is designed to be broad band, allowing the Beacon Wakeup signal to pass through to the endpoint device.

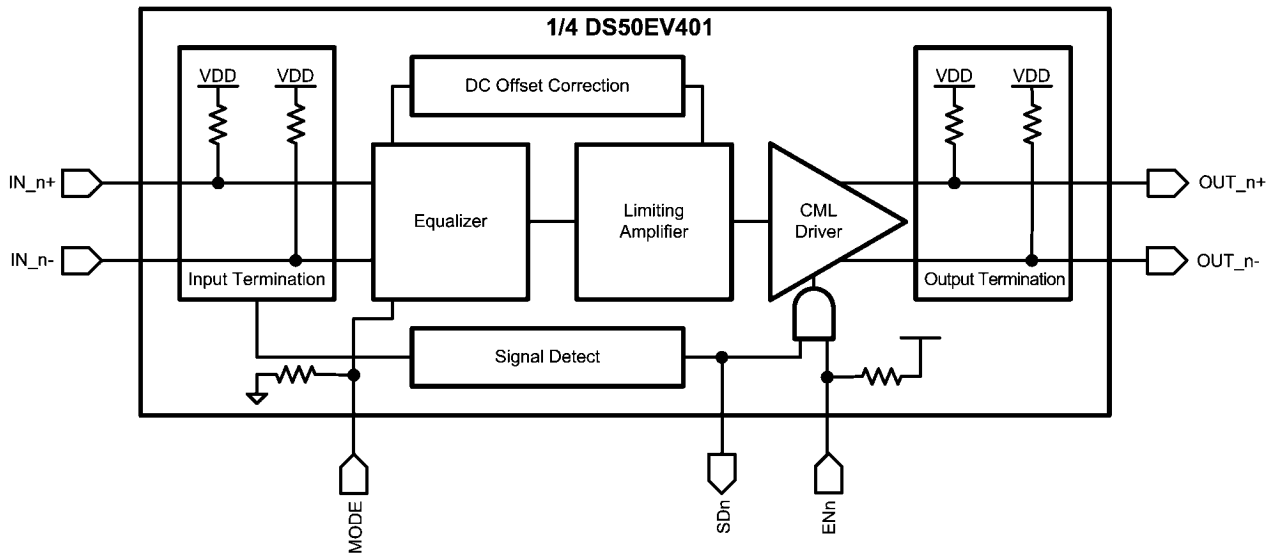

30050505

FIGURE 6. General Block Diagram

### Data Channels

The DS50EV401 consists of four data channels. Each channel provides input termination, receiver equalization, signal limiting, offset cancellation, and a CML output driver, as shown in Figure 6. The data channels support two levels of equalization, controlled by the pin MODE. The equalization levels are set simultaneously on all 4 channels, as described in Table 1.

When an idle condition is sensed on a channel's input, the transmit driver is automatically placed into electrical idle

mode. The common mode voltage is set, and the differential output is forced to zero. To save power, the output driver current is powered off when the device is in electrical idle mode. All other circuits maintain their bias currents allowing a fast recovery from idle to the active state. Electric idle is performed on a per channel basis, and several channels can be in idle while others are actively passing data.

TABLE 1. MODE Control Table

| 6 mil microstrip FR4 trace length (in) | 24 AWG Twin-AX cable length (m) | Frequency          | Channel Loss   | MODE |
|--|---------------------------------|--------------------|----------------|------|
| 0-30                                   | 0-7                             | 8 Gbps             | 16 dB          | 0    |
| 0-40                                   | 0-10                            | 5 Gbps<br>2.5 Gbps | 14 dB<br>20 dB | 1    |



## Applications Information

### BEACON WAKEUP

The DS50EV401 signal path is designed to be broadband, allowing a low frequency signal, such as the Beacon Wakeup

used by the PCI Express protocol, to pass through the device. The AC coupling capacitors used to connect the DS50EV401 to the rest of the system limit the fidelity of the Beacon signal. Therefore, a minimum capacitance of 75nF, as shown in *Figure 7*, is required for proper operation.

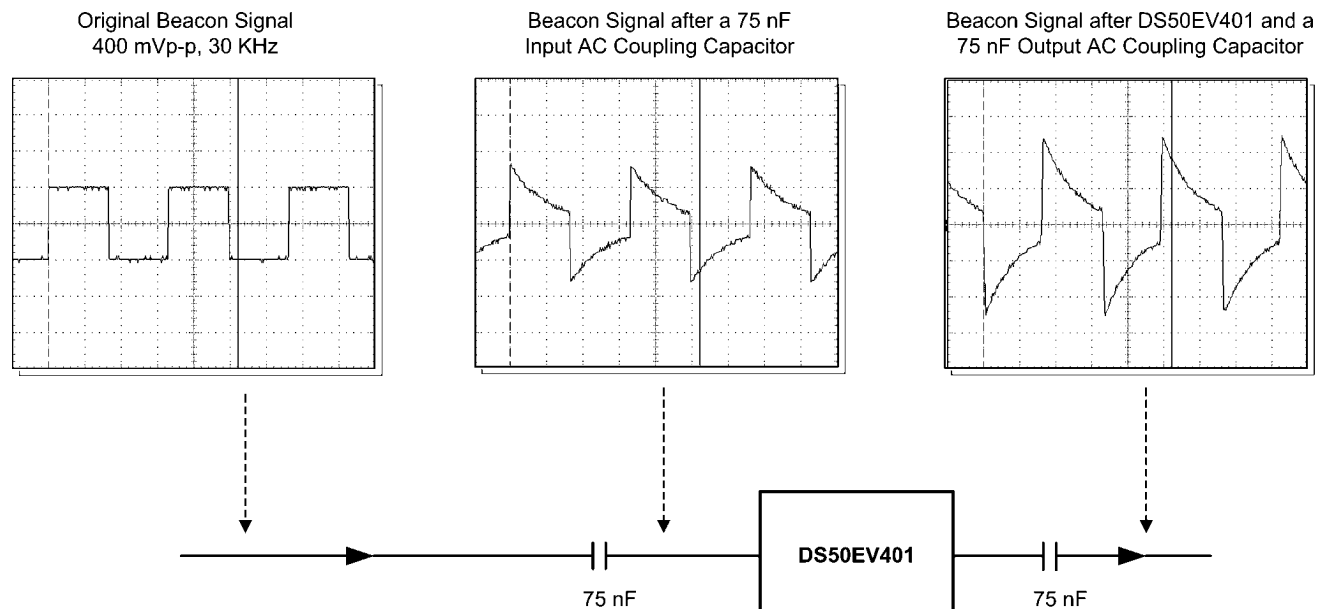

30050507

FIGURE 7. Example of Passing Beacon Signal

### GENERAL RECOMMENDATIONS

The DS50EV401 is a high performance device capable of delivering excellent performance. In order to extract full performance from the device in a particular application, good high-speed design practices must be followed. National Semiconductor's LVDS Owner's Manual, provides detailed information about managing signal integrity and power delivery to get the most from your design.

### PCB LAYOUT CONSIDERATIONS FOR DIFFERENTIAL PAIRS

The CML inputs and outputs must have a controlled differential impedance of  $100\Omega$ . It is preferable to route CML lines exclusively on one layer of the board, particularly for the input traces. The use of vias should be avoided if possible. If vias must be used, they should be used sparingly and must be placed symmetrically for each side of a given differential pair. Route the CML signals away from other signals and noise sources on the printed circuit board. See AN-1187 for additional information on LLP packages.

### PACKAGE FOOTPRINT / SOLDERING

See National's Application Note number 1187, "Leadless Leadframe Package" for information on PCB footprint and soldering recommendations.

### POWER SUPPLY BYPASSING

Two approaches are recommended to ensure that the DS50EV401 is provided with an adequate power supply. First, the supply ( $V_{DD}$ ) and ground (GND) pins should be connected to power planes routed on adjacent layers of the printed circuit board. The layer thickness of the dielectric should be minimized so that the  $V_{DD}$  and GND planes create a low inductance supply with distributed capacitance. Second, careful attention to supply bypassing through the proper use of bypass capacitors is required. A  $0.1\mu\text{F}$  bypass capacitor should be connected to each  $V_{DD}$  pin such that the capacitor is placed as close as possible to the DS50EV401. Smaller body size capacitors can help facilitate proper component placement. Additionally, three capacitors with capacitance in the range of  $2.2\mu\text{F}$  to  $10\mu\text{F}$  should be incorporated in the power supply bypassing design as well. These capacitors can be either tantalum or an ultra-low ESR ceramic and should be placed as close as possible to the DS50EV401.

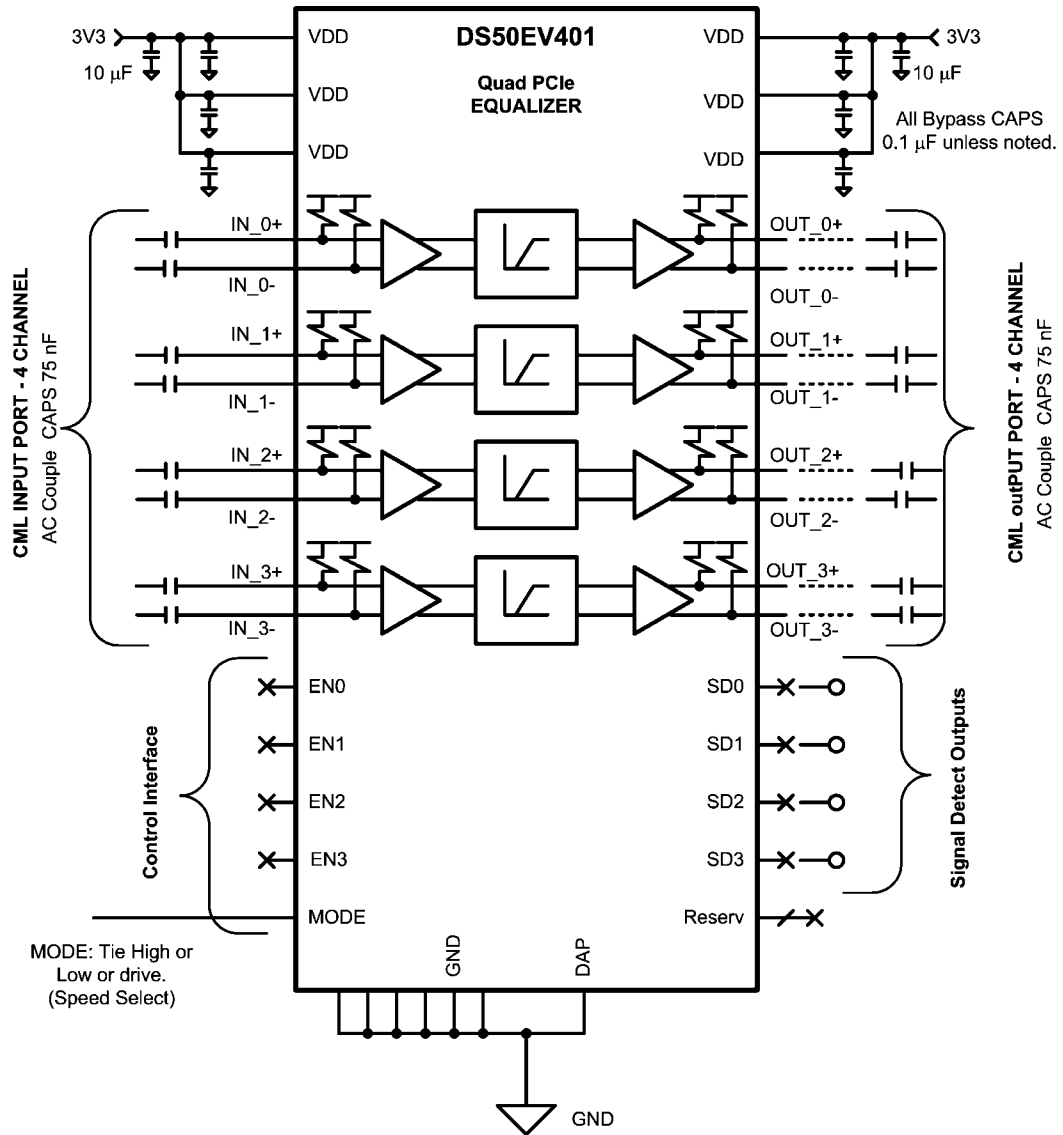

FIGURE 8. Typical Interface Circuit

The CML inputs are AC coupled to the device as shown in *Figure 8*. Internal to the device are 50Ω terminations to  $V_{DD}$ . The CML outputs drive 100 Ω transmission lines and are AC coupled and terminated at their load.

The ENABLE inputs and SIGNAL DETECT outputs are optional. Internal to the device the signal detect circuitry is connected to the enable circuit providing the automatic power management feature. When the No-signal condition is detected, the respective channel is placed in standby mode. The

MODE pin is used to select between low and high data rate equalization settings. Depending upon the application it may be tied High, tied Low, or driven. There are several reserved pins on the device, these are NC pins and should be left open. Power is supplied through six  $V_{DD}$  pins to the device. A 0.1µF capacitor is recommended per pin as close to the device as possible. A larger bulk capacitor is also recommended to be placed near by the device. Ground is supplied to the device via the ground pins and also the DAP.

30050551

# FR4 / BACKPLANE Typical Performance Eye Diagrams

The plots show the unequalized and equalized eye patterns for various interconnects as noted. Unequalized is shown in

the left column and the corresponding equalized eye pattern in shown in the right column.

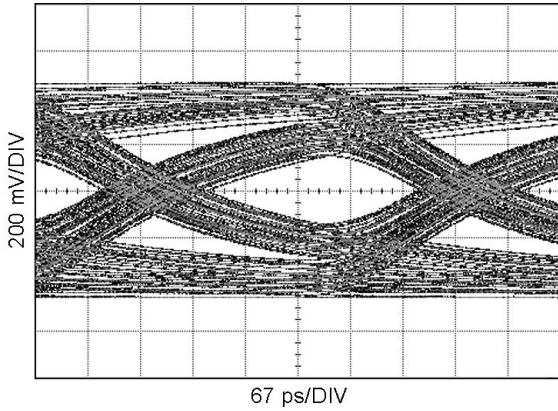

Figure 8. Unequalized Signal (40 in FR4, 2.5 Gbps, PRBS7) 30050508

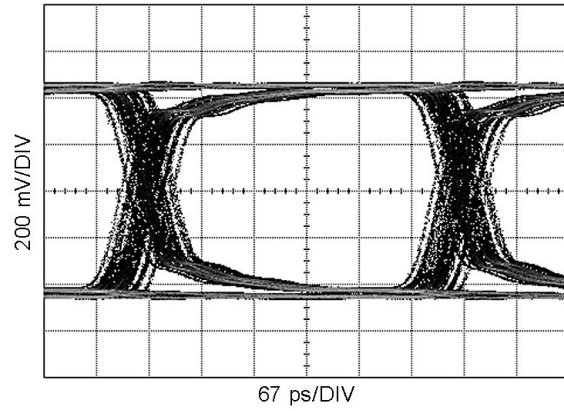

Figure 9. Equalized Signal (40 in FR4, 2.5 Gbps, PRBS7, MODE=1) 30050509

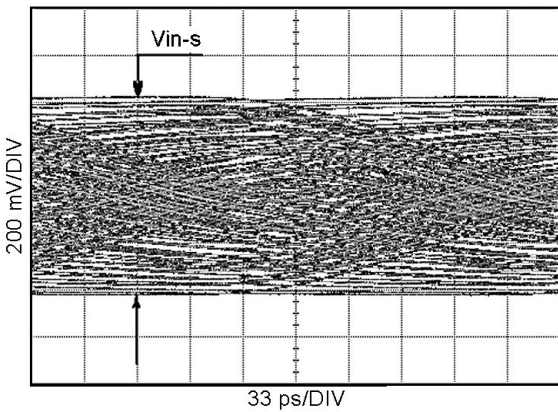

Figure 10. Unequalized Signal (40 in FR4, 5 Gbps, PRBS7) 30050510

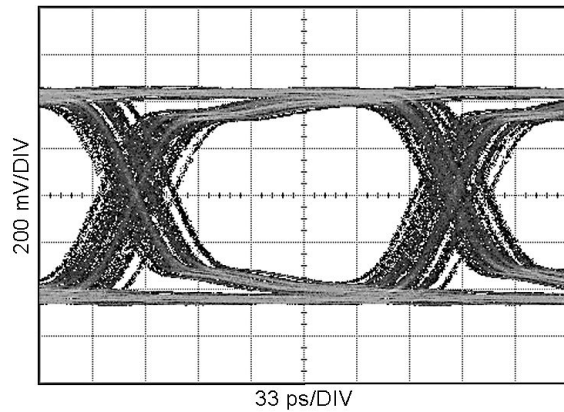

Figure 11. Equalized Signal (40 in FR4, 5 Gbps, PRBS7, MODE=1) 30050511

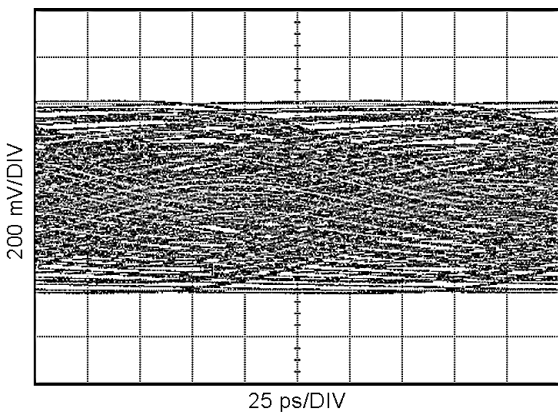

Figure 12. Unequalized Signal (30 in FR4, 8 Gbps, PRBS7) 30050512

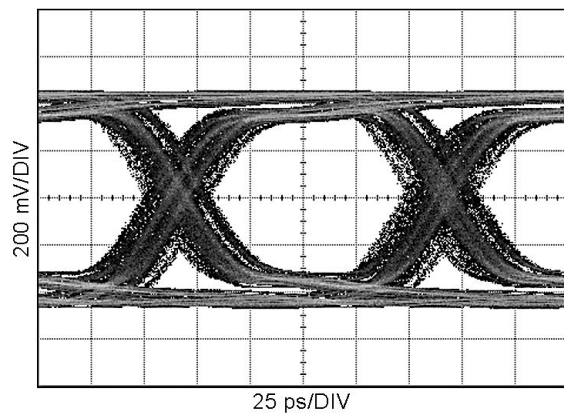

Figure 13. Equalized Signal (30 in FR4, 8 Gbps, PRBS7, MODE=0) 30050513

## Twin-AX CABLES Typical Performance Eye Diagrams

The plots show the unequalized and equalized eye patterns for various interconnects as noted. Unequalized is shown in

the left column and the corresponding equalized eye pattern is shown in the right column.

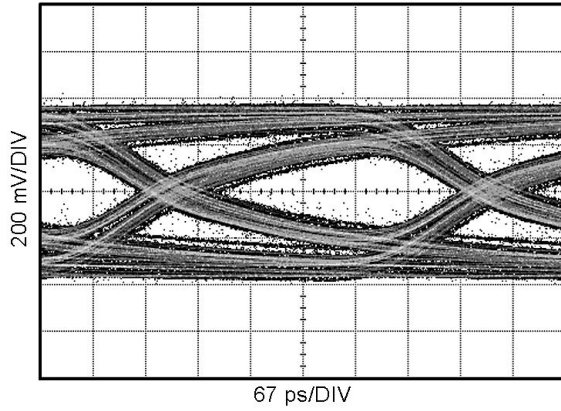

Figure 14. Unequalized Signal (10 m 24 AWG Twin-AX Cable, 2.5 Gbps, PRBS7) <sup>30050514</sup>

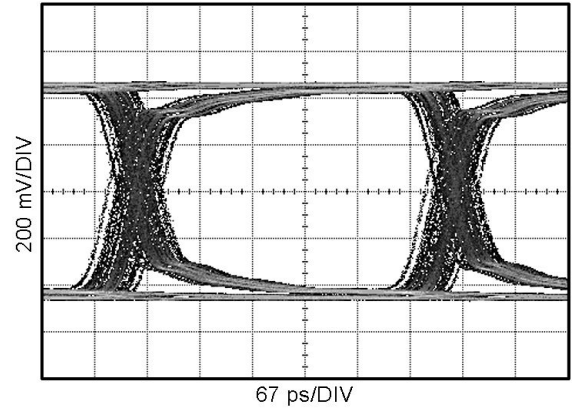

Figure 15. Equalized Signal (10 m 24 AWG Twin-AX Cable, 2.5 Gbps, PRBS7, MODE=1) <sup>30050515</sup>

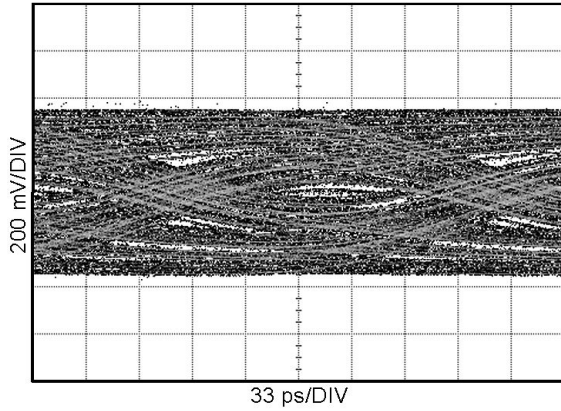

Figure 16. Unequalized Signal (10 m 24 AWG Twin-AX Cable, 5 Gbps, PRBS7) <sup>30050516</sup>

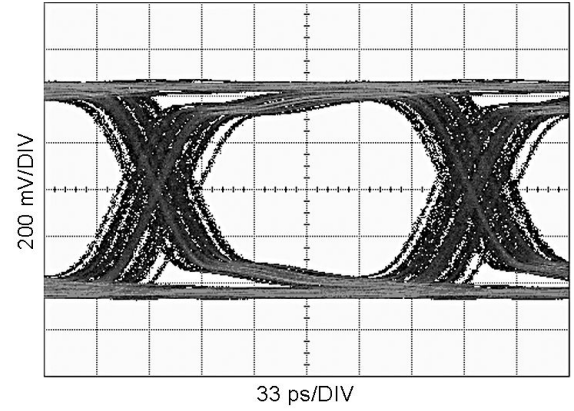

Figure 17. Equalized Signal (10 m 24 AWG Twin-AX Cable, 5 Gbps, PRBS7, MODE=1) <sup>30050517</sup>

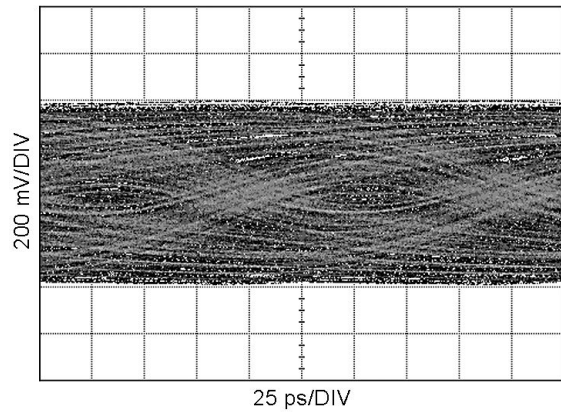

Figure 18. Unequalized Signal (7 m 24 AWG Twin-AX Cable, 8 Gbps, PRBS7) <sup>30050518</sup>

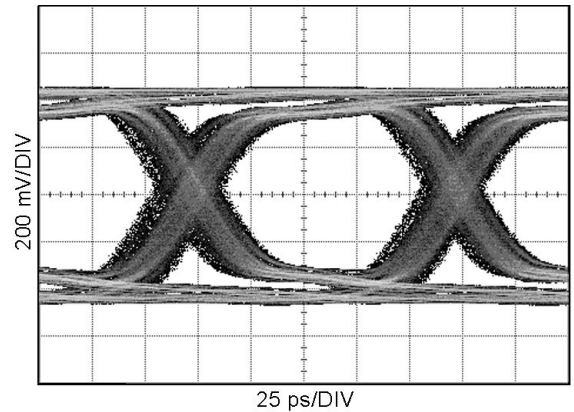
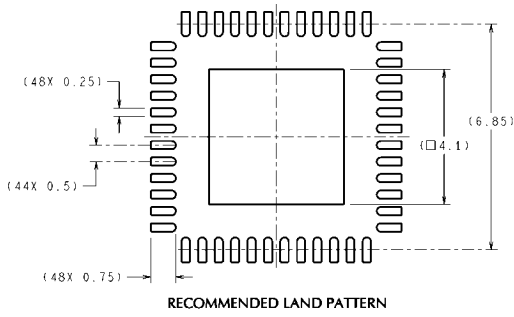
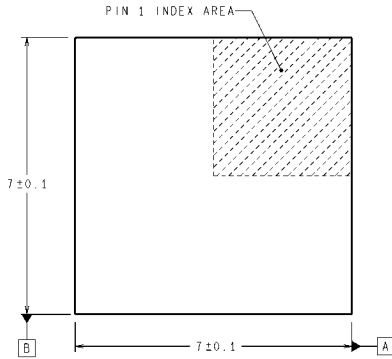

Figure 19. Equalized Signal (7 m 24 AWG Twin-AX Cable, 8 Gbps, PRBS7, MODE=0) <sup>30050519</sup>

**Physical Dimensions** inches (millimeters) unless otherwise noted



RECOMMENDED LAND PATTERN



DIMENSIONS ARE IN MILLIMETERS  
DIMENSIONS IN ( ) FOR REFERENCE ONLY

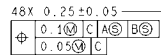
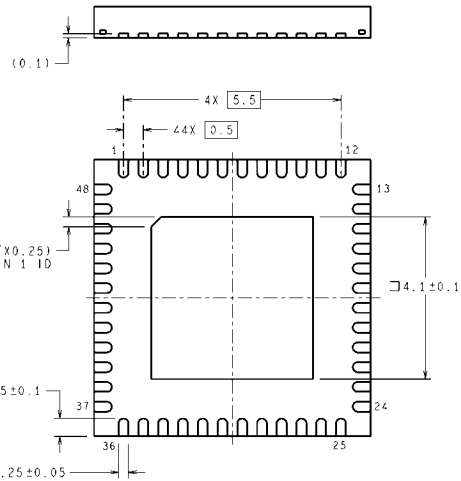
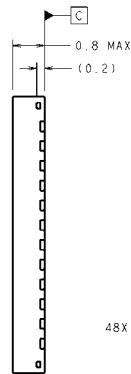

SQA48D (Rev A)

**7mm x 7mm 48-pin LLP Package**  
**Order Number DS50EV401SQ**  
**Package Number SQA48D**

## Notes

For more National Semiconductor product information and proven design tools, visit the following Web sites at:

| Products                       |  | Design Support          |  |
|--------------------------------|--|-------------------------|--|
| Amplifiers                     | <a href="http://www.national.com/amplifiers">www.national.com/amplifiers</a>   | WEBENCH                 | <a href="http://www.national.com/webench">www.national.com/webench</a>             |
| Audio                          | <a href="http://www.national.com/audio">www.national.com/audio</a>             | Analog University       | <a href="http://www.national.com/AU">www.national.com/AU</a>                       |
| Clock Conditioners             | <a href="http://www.national.com/timing">www.national.com/timing</a>           | App Notes               | <a href="http://www.national.com/appnotes">www.national.com/appnotes</a>           |
| Data Converters                | <a href="http://www.national.com/adc">www.national.com/adc</a>                 | Distributors            | <a href="http://www.national.com/contacts">www.national.com/contacts</a>           |
| Displays                       | <a href="http://www.national.com/displays">www.national.com/displays</a>       | Green Compliance        | <a href="http://www.national.com/quality/green">www.national.com/quality/green</a> |
| Ethernet                       | <a href="http://www.national.com/ethernet">www.national.com/ethernet</a>       | Packaging               | <a href="http://www.national.com/packaging">www.national.com/packaging</a>         |
| Interface                      | <a href="http://www.national.com/interface">www.national.com/interface</a>     | Quality and Reliability | <a href="http://www.national.com/quality">www.national.com/quality</a>             |
| LVDS                           | <a href="http://www.national.com/lvds">www.national.com/lvds</a>               | Reference Designs       | <a href="http://www.national.com/refdesigns">www.national.com/refdesigns</a>       |
| Power Management               | <a href="http://www.national.com/power">www.national.com/power</a>             | Feedback                | <a href="http://www.national.com/feedback">www.national.com/feedback</a>           |
| Switching Regulators           | <a href="http://www.national.com/switchers">www.national.com/switchers</a>     |                         |  |
| LDOs                           | <a href="http://www.national.com/lido">www.national.com/lido</a>               |                         |  |
| LED Lighting                   | <a href="http://www.national.com/led">www.national.com/led</a>                 |                         |  |
| PowerWise                      | <a href="http://www.national.com/powerwise">www.national.com/powerwise</a>     |                         |  |
| Serial Digital Interface (SDI) | <a href="http://www.national.com/sdi">www.national.com/sdi</a>                 |                         |  |
| Temperature Sensors            | <a href="http://www.national.com/tempsensors">www.national.com/tempsensors</a> |                         |  |
| Wireless (PLL/VCO)             | <a href="http://www.national.com/wireless">www.national.com/wireless</a>       |                         |  |

THE CONTENTS OF THIS DOCUMENT ARE PROVIDED IN CONNECTION WITH NATIONAL SEMICONDUCTOR CORPORATION ("NATIONAL") PRODUCTS. NATIONAL MAKES NO REPRESENTATIONS OR WARRANTIES WITH RESPECT TO THE ACCURACY OR COMPLETENESS OF THE CONTENTS OF THIS PUBLICATION AND RESERVES THE RIGHT TO MAKE CHANGES TO SPECIFICATIONS AND PRODUCT DESCRIPTIONS AT ANY TIME WITHOUT NOTICE. NO LICENSE, WHETHER EXPRESS, IMPLIED, ARISING BY ESTOPPEL OR OTHERWISE, TO ANY INTELLECTUAL PROPERTY RIGHTS IS GRANTED BY THIS DOCUMENT.

TESTING AND OTHER QUALITY CONTROLS ARE USED TO THE EXTENT NATIONAL DEEMS NECESSARY TO SUPPORT NATIONAL'S PRODUCT WARRANTY. EXCEPT WHERE MANDATED BY GOVERNMENT REQUIREMENTS, TESTING OF ALL PARAMETERS OF EACH PRODUCT IS NOT NECESSARILY PERFORMED. NATIONAL ASSUMES NO LIABILITY FOR APPLICATIONS ASSISTANCE OR BUYER PRODUCT DESIGN. BUYERS ARE RESPONSIBLE FOR THEIR PRODUCTS AND APPLICATIONS USING NATIONAL COMPONENTS. PRIOR TO USING OR DISTRIBUTING ANY PRODUCTS THAT INCLUDE NATIONAL COMPONENTS, BUYERS SHOULD PROVIDE ADEQUATE DESIGN, TESTING AND OPERATING SAFEGUARDS.

EXCEPT AS PROVIDED IN NATIONAL'S TERMS AND CONDITIONS OF SALE FOR SUCH PRODUCTS, NATIONAL ASSUMES NO LIABILITY WHATSOEVER, AND NATIONAL DISCLAIMS ANY EXPRESS OR IMPLIED WARRANTY RELATING TO THE SALE AND/OR USE OF NATIONAL PRODUCTS INCLUDING LIABILITY OR WARRANTIES RELATING TO FITNESS FOR A PARTICULAR PURPOSE, MERCHANTABILITY, OR INFRINGEMENT OF ANY PATENT, COPYRIGHT OR OTHER INTELLECTUAL PROPERTY RIGHT.

### LIFE SUPPORT POLICY

**NATIONAL'S PRODUCTS ARE NOT AUTHORIZED FOR USE AS CRITICAL COMPONENTS IN LIFE SUPPORT DEVICES OR SYSTEMS WITHOUT THE EXPRESS PRIOR WRITTEN APPROVAL OF THE CHIEF EXECUTIVE OFFICER AND GENERAL COUNSEL OF NATIONAL SEMICONDUCTOR CORPORATION.** As used herein:

Life support devices or systems are devices which (a) are intended for surgical implant into the body, or (b) support or sustain life and whose failure to perform when properly used in accordance with instructions for use provided in the labeling can be reasonably expected to result in a significant injury to the user. A critical component is any component in a life support device or system whose failure to perform can be reasonably expected to cause the failure of the life support device or system or to affect its safety or effectiveness.

National Semiconductor and the National Semiconductor logo are registered trademarks of National Semiconductor Corporation. All other brand or product names may be trademarks or registered trademarks of their respective holders.

Copyright© 2008 National Semiconductor Corporation

For the most current product information visit us at [www.national.com](http://www.national.com)



**National Semiconductor Americas Technical Support Center**  
 Email: [support@nsc.com](mailto:support@nsc.com)  
 Tel: 1-800-272-9959

**National Semiconductor Europe Technical Support Center**  
 Email: [europe.support@nsc.com](mailto:europe.support@nsc.com)  
 German Tel: +49 (0) 180 5010 771  
 English Tel: +44 (0) 870 850 4288

**National Semiconductor Asia Pacific Technical Support Center**  
 Email: [ap.support@nsc.com](mailto:ap.support@nsc.com)

**National Semiconductor Japan Technical Support Center**  
 Email: [jpn.feedback@nsc.com](mailto:jpn.feedback@nsc.com)